

AUDIX Cab Grabber™

FEATURES:

- * An innovative miking solution for guitar amps and cabinets
- * Allows for precise positioning
- * Simple, elegant, compact and easy to use
- * No tools required
- * Adjustable, tension held
- * Mic arm hand tightens firmly into position
- * Holds mics weighing up to 1lb
- * Works on cabinets with flat surface or recessed edge
- * Will clamp to side of cabinet or over top
- * Fits 8-14 inch cabinets and amps
- * Durable steel construction

USER TIPS:

One of the advantages of the Cab Grabber is that it can be placed on either side of the cabinet and positioned at any height. It is also possible to mount the Cab Grabber over the top of the cabinet, which is very useful on cabinets having an angled front baffle.

Going for sound: There are different schools of thought as to where to place the microphone relative to the speakers.

1. Edge mounting: The most popular position is just inside the edge of one of the speakers. This position somewhat softens the tone. If the cabinet has more than one speaker, pick the speaker that sounds the best. The mic could be either at a 90 degree angle, or for more tone variation you can angle the mic slightly off axis, but not too much or you will lose the intensity of the pickup. The mic is generally very close to the grill cloth (within one inch).

2. Towards center: The center of the speaker is considered to be harsh and not desirable by most. However, as you move the mic from the edge of the speakers towards the center, you will add more "bite" to the tone and only by experimentation will you find the "sweet spot" for your particular sound.

3. Large diaphragm mic: In addition to holding a dynamic mic (like the Audix i-5) The Cab Grabber is also capable of holding a large diaphragm microphone up to 1 lb (like the Audix CX112). A large diaphragm condenser offers yet another option for attaining a signature sound.

DIMENSIONS (mm):

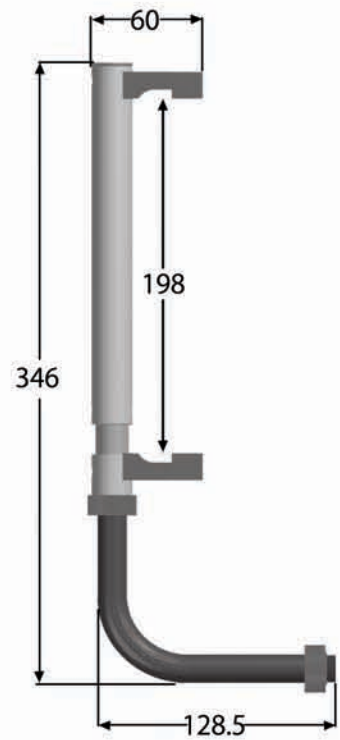

HOW TO INSTALL:



Step 1: Grip the neck and rear of the Cab Grabber so that it will be in a position to slide back and forth.



Step 2: Place the rear grip into position first on the back of the cabinet. Then pull the front grip out and slide it over the front of the cabinet. Adjust so the bar is in a level position.



Step 3: Adjust the neck choke to the desired position by hand tightening the locking nut.



Step 4: Adjust the axis of the microphone into its final position.

Made in Taiwan



6 87471 13140 4

AUDIX
MICROPHONES

Phone 503-682-6933 Fac 503-6827114
Audix Corporation P.O. Box 4010 Wilsonville, OR 97070
www.audixusa.com

***DISCLAIMER: Audix is not responsible for any damages caused to amplifiers, cabinets or speakers as a result of using this product. When used properly, this product is safe to use and harmless to most cabinet coverings and finishes. Extra care should be taken with vintage and collectible amplifiers and speakers to reduce blemishes, dents, and nicks in the coverings and finishes.